

1200LB POLY DUMP CART FOUR WHEELS



Instruction & Assembly

SAVE THESE INSTRUCTIONS FOR FUTURE REFERENCE

Table of Contents

General Warnings and Rules	3
Hazard Signal Word Definition	4
Controls and Features Identification.....	5
Assembly Instructions	6, 7, 8
Operation Instructions	9
Maintenance and Storage	10
Specification.....	11
Parts Drawing & Parts List	12, 13
Limited Warranty	14

GENERAL WARNINGS

READ and UNDERSTAND this manual completely before using Utility Dump Cart.

Operator must read and understand all safety and warning information, operating instructions, maintenance and storage instructions before operating this equipment. Failure to properly operate and maintain the utility dump cart could result in serious injury to the operator or bystanders.

Operation Warnings

- Do not at any time carry passengers sit or stand on the cart.
- Do not allow children to play on, stand upon or climb in the cart.
- Always inspect the cart before using to assure it is in good working condition.
- Replace or repair damaged or worn parts immediately.
- Always check and tighten hardware and assembled parts before operation.
- Do not exceed equipment maximum load capacity of 1200lb.
- Avoid large holes and ditches when transporting loads.
- Be careful when operating on steep grades (hill) the cart may tip over.
- Always operate at reduce speed in rough terrain, along creeks, ditches and on hillsides.
- Do not operate close to creeks, ditches and public highways.
- To avoid personal injury and/or equipment damage **DO NOT EXCEED 16 MPH.**
- Always use caution when loading and unloading the cart.
- Only tow with recommended vehicles (Lawn/Garden Tractors and ATVs).
- Always secure and lock dump cart to the vehicle hitch before operating.

Crush and Cut Hazards

- Always keep hands and feet clear from moving parts while operating the equipment.
- Always clear and keep work area clean when operating.
- Always wear safety gear, eye protection, gloves and work boots when operating the dump cart.





WARNING

The warnings, cautions, and instructions outlined in this instruction manual cannot cover all possible conditions or situations that may occur. It must be understood by the operator that common sense and caution are factors which cannot be built into this product and must be supplied by the operator.

Assembly Is Required

This product requires assembly before use. See "Assembly" section for instructions. Because of the weight and/or size of the utility dump cart, it is recommended that another adult be present to assist with the assembly. **INSPECT ALL COMPONENTS** closely upon receipt to make sure no components are missing or damaged.

Hazard Signal Word Definitions

	<p>This is the safety alert symbol. It is used to alert you to potential personal injury hazards. Obey all safety messages that follow this symbol to avoid possible injury or death.</p>
	<p>DANGER indicates an imminently hazardous situation which, if not avoided, will result in death or serious injury.</p>
	<p>WARNING indicates a potentially hazardous situation which, if not avoided, could result in death or serious injury.</p>
	<p>CAUTION indicates a potentially hazardous situation which, if not avoided, may result in minor or moderate injury.</p>
	<p>CAUTION used without the safety alert symbol indicates a potentially hazardous situation which, if not avoided, may result in property damage.</p>

ABOUT YOUR UTILITY DUMP CART

This utility dump cart has a rugged steel construction and is designed to carry a wide range of materials. The dump cart will easily haul up to 1200lbs of tools, firewood, animal feed, trash, landscaping materials, cement or anything else that needs to be moved. Low profile cart makes loading and un-loading fast and convenient. Never exceed the rated load capacity of 1200lbs when operating the utility dump cart.

Technical specifications on the utility dump cart are provided in the "Specifications" section of this manual.

Controls and Features Identification

Read this owner's manual before operating the equipment. Familiarize yourself with the location and function of the controls and features. Save this manual for future reference.



- 1) **Utility Cart Box** – Do not exceed rated load capacity 1200lb.
- 2) **Tires** – Do not exceed the recommended rate 28 PSI.
- 3) **Hitch** – Pin-type design use only with approve vehicles.
- 4) **Release Pedal**– Release the cart bed.



CAUTION

Read and follow all instructions for assembly and operation. Failure to properly assemble this equipment could result in serious injury to the user or bystanders, or cause equipment damage.

UTILITY DUMP CART COMPONENT PARTS AND ASSEMBLY

Take all parts out of the shipping crate and inspect components to ensure there are no missing pieces before starting to assemble the utility dump cart follow steps 1 through 4.

TOOLS REQUIRED

- Screw Driver
- 17mm & 19mm Wrench

Assembly Instructions

STEP 1: Attach the Hitch Tube

1. Connect trailer pivot tube (#10) and support plate (#8) to the wheel stand (#1) using cup head square neck bolt M12x80 (#36), large flat washer $\text{\O}12$ (#27) and nylon lock nut M12 (#32).
2. Connect hitch tube (#7) to the trailer pivot tube (#10) using cup head square neck bolt M12x80 (#36), large flat washer $\text{\O}12$ (#27) and nylon lock nut M12 (#32).

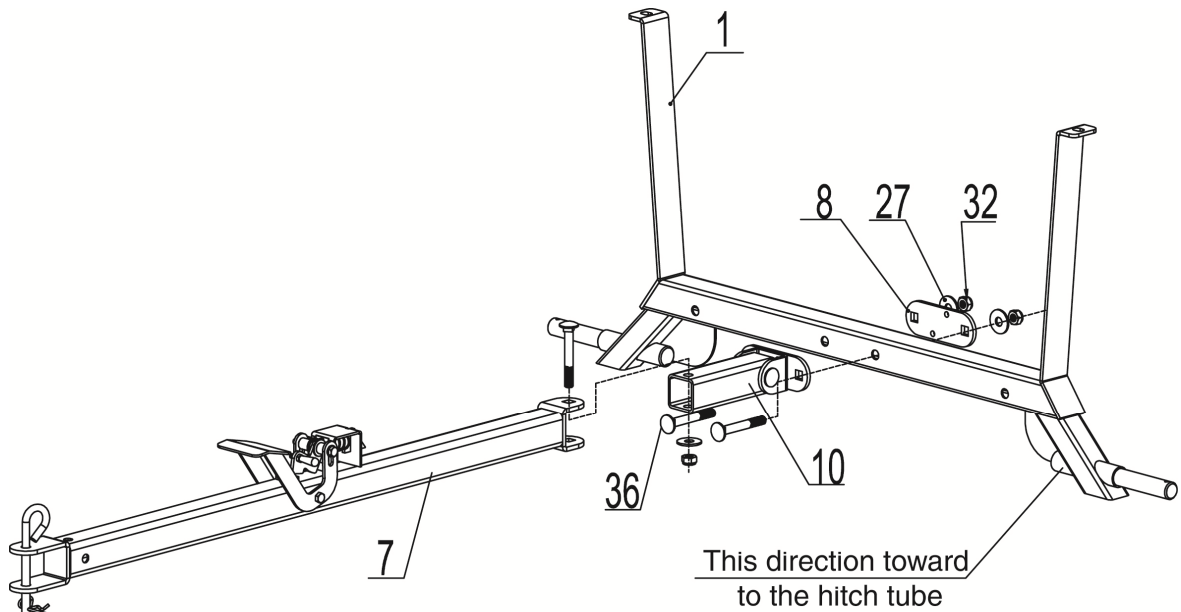

STEP 2: Attach the Tires

1. Attach axle pivot assembly (#3) to the axle, using the flat washer $\text{\O}24$ (#26) and O lock ring (#22). Then attach the tires (#5) to the axle pivot assembly, using the flat washer $\text{\O}24$ (#26) and O lock ring (#22).

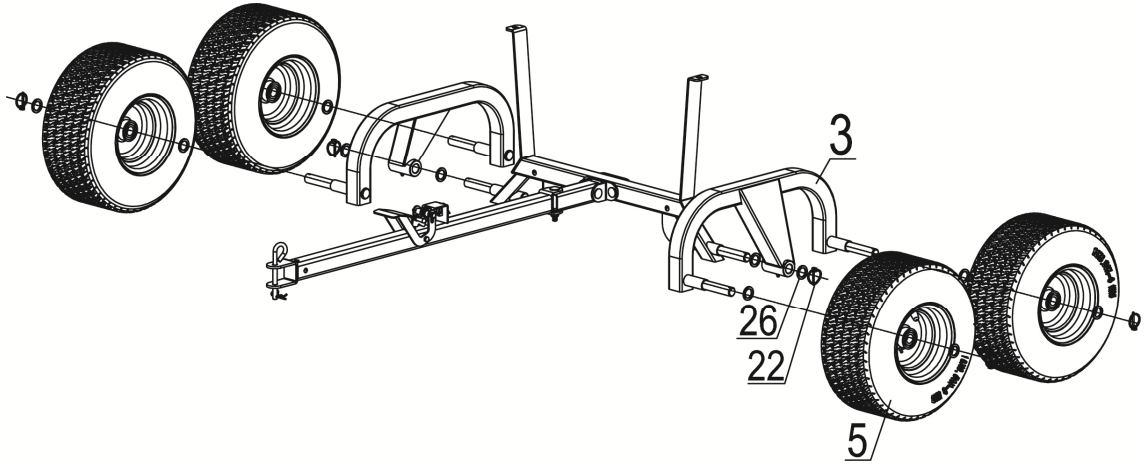

STEP 3: Attach the U-Frame

2. Attach the u-frame (#2) to the wheel stand using the cup head square neck bolt M12x80 (#36), large flat washer $\text{\O}12$ (#27) and nylon lock nut M12 (#32).

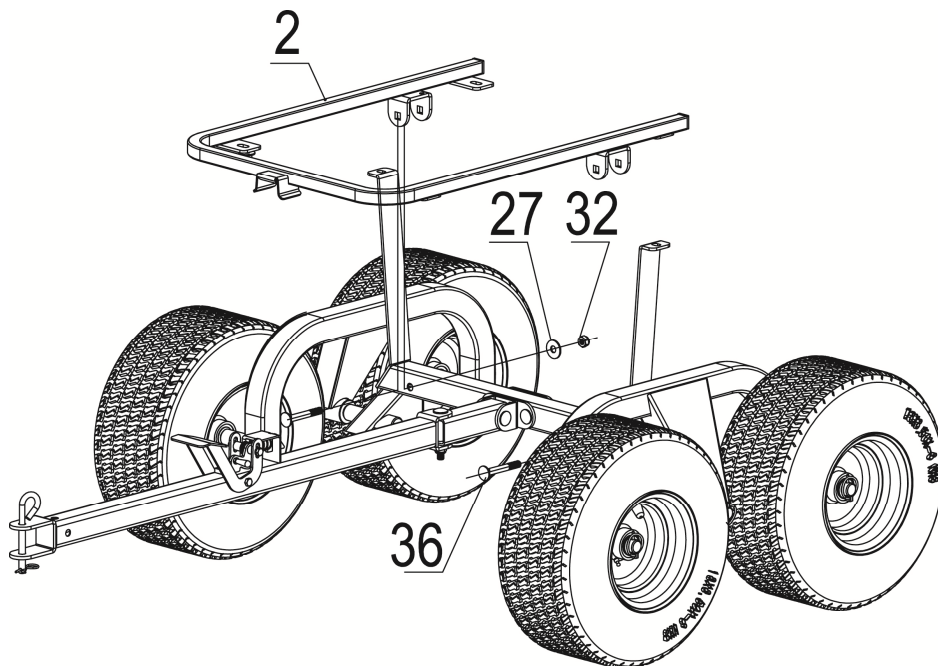

STEP 4: Attach the Poly Tray

1. Attach the poly tray (#4) to the frame, secure with the cross pan head bolt M10x25 (#37), square gasket (#17), large flat washer Ø10 (#28) and nylon lock nut M10 (#31).
2. Secure the edge of poly tray to the frame with cross pan head bolt M10x25 (#37), flat washer Ø10 (#28) and nylon lock nut M10 (#31). Don't tighten the bolts.
3. Attach hand shank (#6) to the poly tray (#4) using the large flat head bolt M10x45 (#38), large flat washer Ø10 (#28) and nylon lock nut M10 (#31).

Note: Tighten all bolts after the four bolts are fixed.

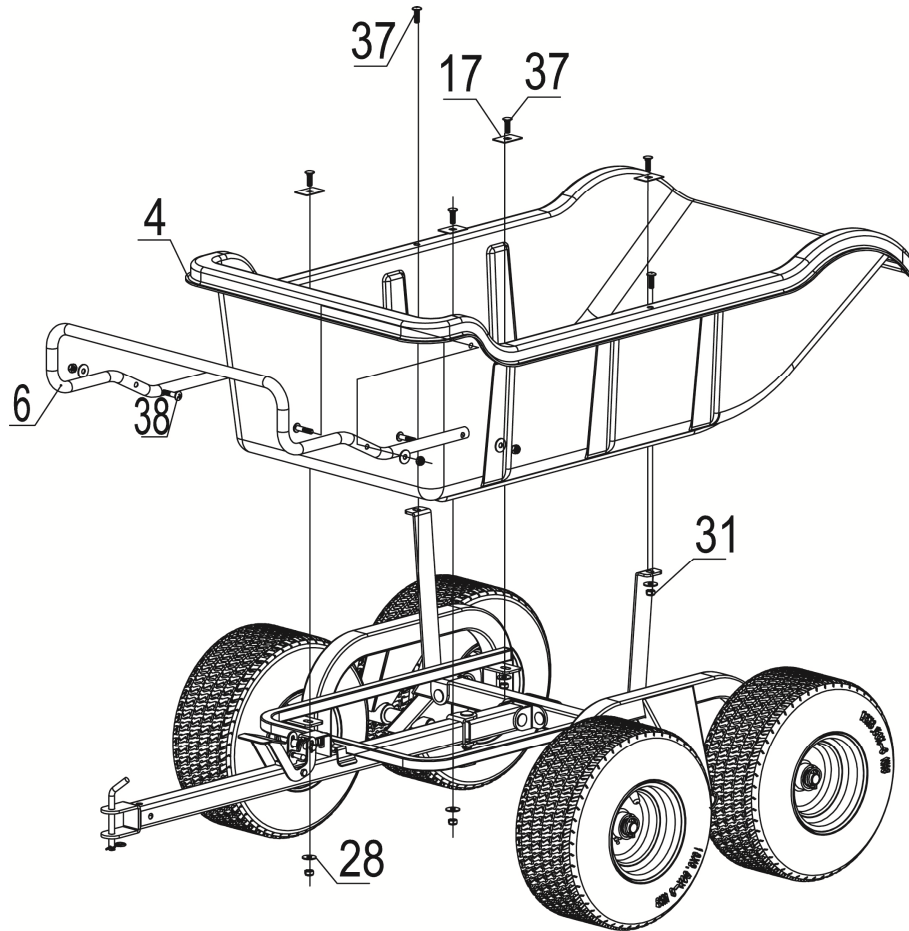

Operation Instructions

WARNING

Before using the utility dump cart, review the instructions below and safety information. Failure to follow these instructions may result in property damage or injury to the operator or bystanders.

USING YOUR UTILITY DUMP CART

1. **DO NOT** exceed rated capacity of 1200lb (544.3kg).
2. **ALWAYS** secure and lock the utility cart to the vehicle hitch before operating.
3. **ONLY** use approved vehicles when towing the dump cart (Lawn/Garden Tractors and ATVs)
4. **NEVER** tow the utility dump cart with box raised.
5. **DO NOT** over fill the utility dump cart. Over flow loads can cause the cart and towing vehicle to lose traction and skid out of control.
6. **ONLY** fill the dump cart to a comfortable dumping load. Extremely heavy loads will be difficult to operate and dump.
7. **ALWAYS** use the dump cart for its intended purpose.
8. **ALWAYS** make sure that the tow vehicle and the combined weight of the operator **MUST BE** greater than the load of the cart weight for proper control.
9. **DO NOT** use cart on public highways or roads.
10. **NEVER** exceed 16mph when towing the dump cart.
11. **DO NOT** make sharp turns that may cause the Lawn/Garden Tractor or ATV tires to rub against the utility dump cart.
12. **ALWAYS** slow down before turning.
13. **ALWAYS** use caution when backing the utility cart. To avoid the cart from “jack-knifing” always back up in a straight line.

Operation Instructions

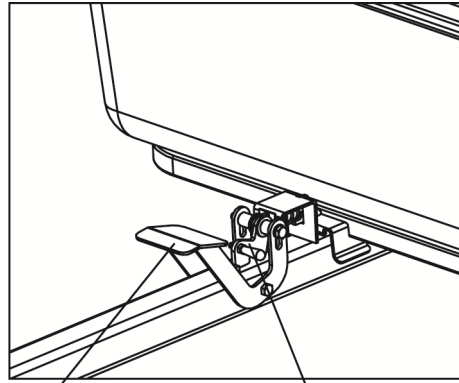

Pedal Safety Device

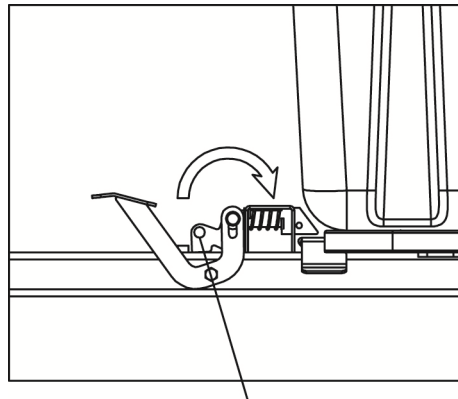

Flip Up Safety Device

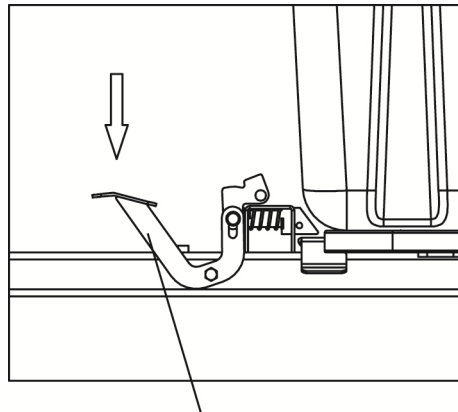

Press the Pedal Down

1. Flip up the safety device and press the pedal down to release the bed for dumping.
2. When towing the cart, flip down the safety device to lock the bed to avoid accidental dumping.

Warning: Do not press the pedal after the safety device is locked.

Maintenance and Storage



WARNING

Improper maintenance and storage of the utility dump cart may void your warranty.

MAINTENANCE

- After each use clean material out of the cart box.
- Rinse/dry inside and outside of the dump cart after each use.
- Before operating make sure the tires have the RECOMMENDED TIRE PRESSURE 28 PSI.
- Regularly grease the axle and the wheel bearing area or when needed.
- Periodically check all fasteners for tightness.
- Annually clean and lightly lubricate parts.
- Use a glossy enamel spray paint to touch up scratched or worn painted metal surfaces.
- Never exceed load capacity rating of 1200lb (544.3kg) it will damage the utility dump cart.

IMPORTANT:

If a part needs replacement, only use parts that meet the manufacturer's specifications. Replacement parts that do not meet specifications may result in a safety hazard or poor operation.

STORAGE

- Never allow material to remain in the utility dump cart for extended periods of time.
- Before storing make sure the cart is clean and dry for years of trouble free service.
- Store indoors or protected area during severe weather and winter months.
- When storing outside always keep the tongue a little higher than the back of the cart to allow the moisture to easily run out the back and will not accumulate in the box.

Specifications

Load Capacity	1200lb
Box Dimensions	61.4"x31.0"x18.1"
Overall Dimensions	85"x49.8"x31.5"
Wheel Size	18"
Wheel Type	Pneumatic
Hitch Type	Pin Style
Tire Pressure (PSI)	28

Parts Drawing & Parts List

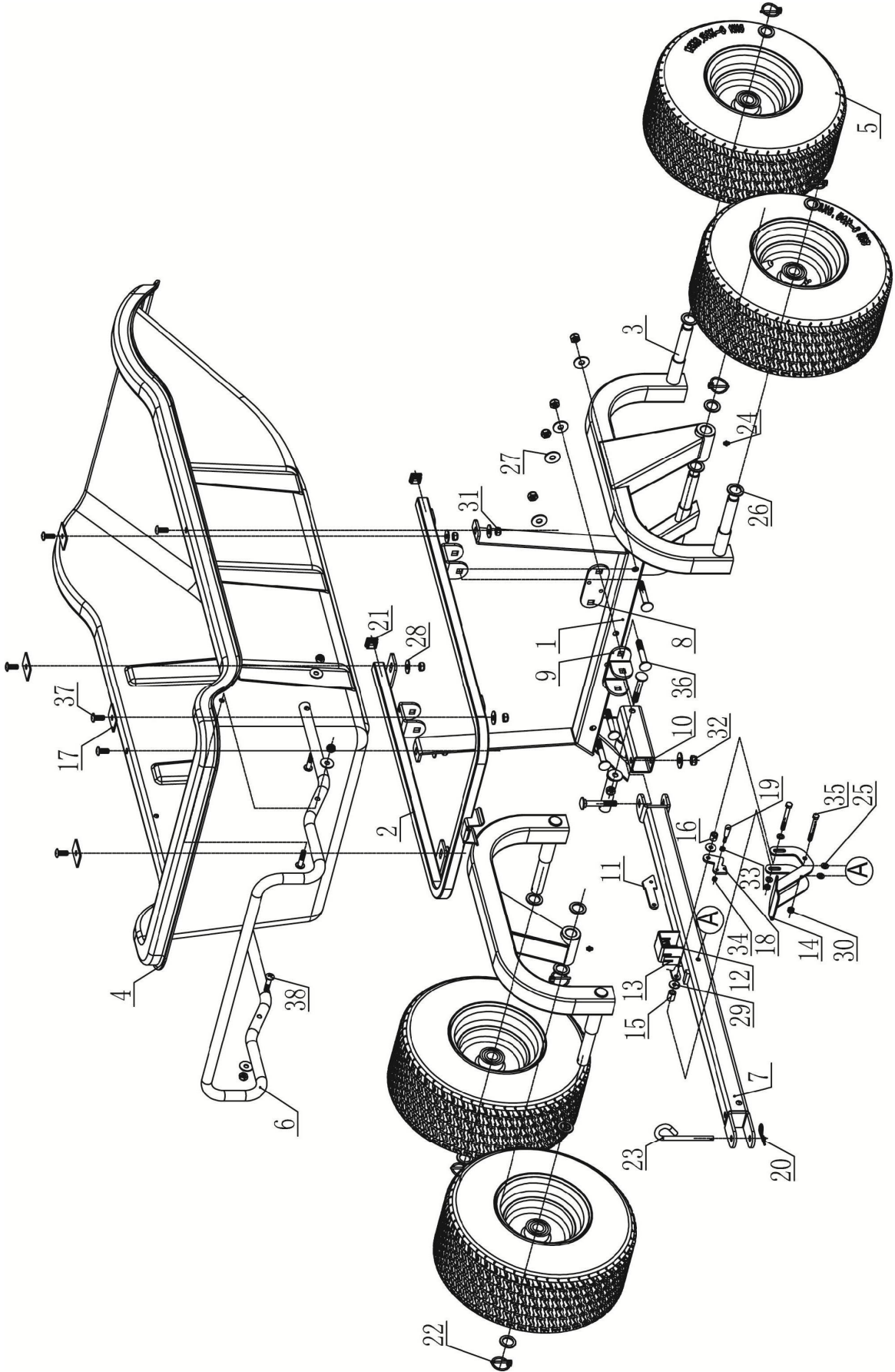

Parts Drawing & Parts List

Ref#	Drawing No.	Description	Qty
1	DCP1200-01000	Wheel Stand	1
2	DCP1200-02000	U-Frame	1
3	DCP1200-03000	Axle Pivot Assembly	2
4	DCP1200-00001	Poly Tray	1
5	DCP1200-00002	Tire	4
6	DCP1200-00003	Hand Shank	1
7	DCP1000-03000	Hitch Tube	1
8	DCP1000-04001	Support Plate	1
9	DCP01000-04000	Hitch Pull Weldment	1
10	DCP1000-00003	Trailer Pivot Tube	1
11	DCP0600-00002	Safety Fork	1
12	DCP0600-00003	Pressure Spring	1
13	DCP0600-00004	Spacer	1
14	DCP0600-04000	Pedal	1
15	DCP0600-00006	Bushing A	1
16	DCP0600-00010	Bushing	1
17	DCP0600-00007	Square Gasket	4
18	DCP0600-00009	Safety Device	1
19	DCP0600-00008	Handle	1
20	LSP25-00012-DX	R Pin Ø3	1
21	M150-00003	Plug	2
22	TS600-00009	O Lock Ring	6
23	N870-00011	Hitch Pin	1
24	9701-06000	Oil Cup	2
25	9301-08000-DX	Flat Washer Ø8	4
26	9301-24000-DX	Flat Washer Ø24	12
27	9302-12000-DX	Large Flat Washer Ø12	6
28	9302-10000- DX	Large Flat Washer Ø10	10
29	9302-08000- DX	Large Flat Washer Ø8	2
30	9206-08000- DX	Nylon Lock Nut M8	2
31	9206-10000- DX	Nylon Lock Nut M10	10
32	9206-12000-DX	Nylon Lock Nut M12	6
33	9201-06000- DX	Hex Nut M6	1
34	9206-06000- DX	Nylon Lock Nut M6	1
35	9101-08075- DX	Hex Bolt M8x75	2
36	9114-12080- DX	Cup Head Square Neck Bolt M12x80	6
37	919901-10025- DX	Cross Pan Head Bolt M10x25	6
38	919901-10045- DX	Cross Pan Head Bolt M10x45	4

Limited Warranty

Warranty

For one year from the date of purchase YTL International will replace for the original purchaser, or repair the utility dump cart. The warranty will not apply to any unit which was not assembled correctly, misused, overloaded or which has been used or operated contrary to our instructions, or which has been repaired or altered by anyone other than an authorized representative.

Warranty Exclusions

This warranty does not cover cosmetic defects such as paint, decals or wear items such as tires. This warranty will not cover failures or problems due to acts of God, or events or forces beyond the control of the manufacturer.

Normal Wear Exclusion

The utility dump cart needs periodic service to perform well. This warranty does not cover repair when normal use has exhausted the life of a part or the equipment as a whole.

Installation, Use and Maintenance Exclusion

This warranty will not apply to parts and/or labor if the utility dump cart has been misused, neglected, involved in an accident, abused, loaded beyond its limits, modified or assembled incorrectly. Normal maintenance is not covered under this warranty.

Limits of Implied Warranty and Consequential Damage Exclusion

YTL International disclaims any obligation to cover any loss of time, use of this product, freight, or any incidental or consequential claim by anyone from using this utility dump cart. THIS WARRANTY IS IN LIEU OF ALL OTHER WARRANTIES, EXPRESS OR IMPLIED, INCLUDING WARRANTIES OF MERCHANTABILITY OR FITNESS FOR A PARTICULAR.

An exchange unit will be subject to the original warranty. The length of the warranty governing the exchanged unit will have the date as the purchase date of the original unit. This warranty gives you certain legal rights which may change from state to state. Your state may also have other rights you may be entitled to that are not listed within this warranty.

Contact Information

YTL International Inc.
17517 Fabrica Way, Suite J
Cerritos, CA 90703
Phone: (888) 723-6534
Phone: (562) 404-8016
Fax: (562) 404-8013
E-mail: parts@ytlinternational.com
Website: www.ytlinternational.com

Warranty & Customer Support Questions

Phone: (888) 723-6534