

125LB TOW-BEHIND SPREADER

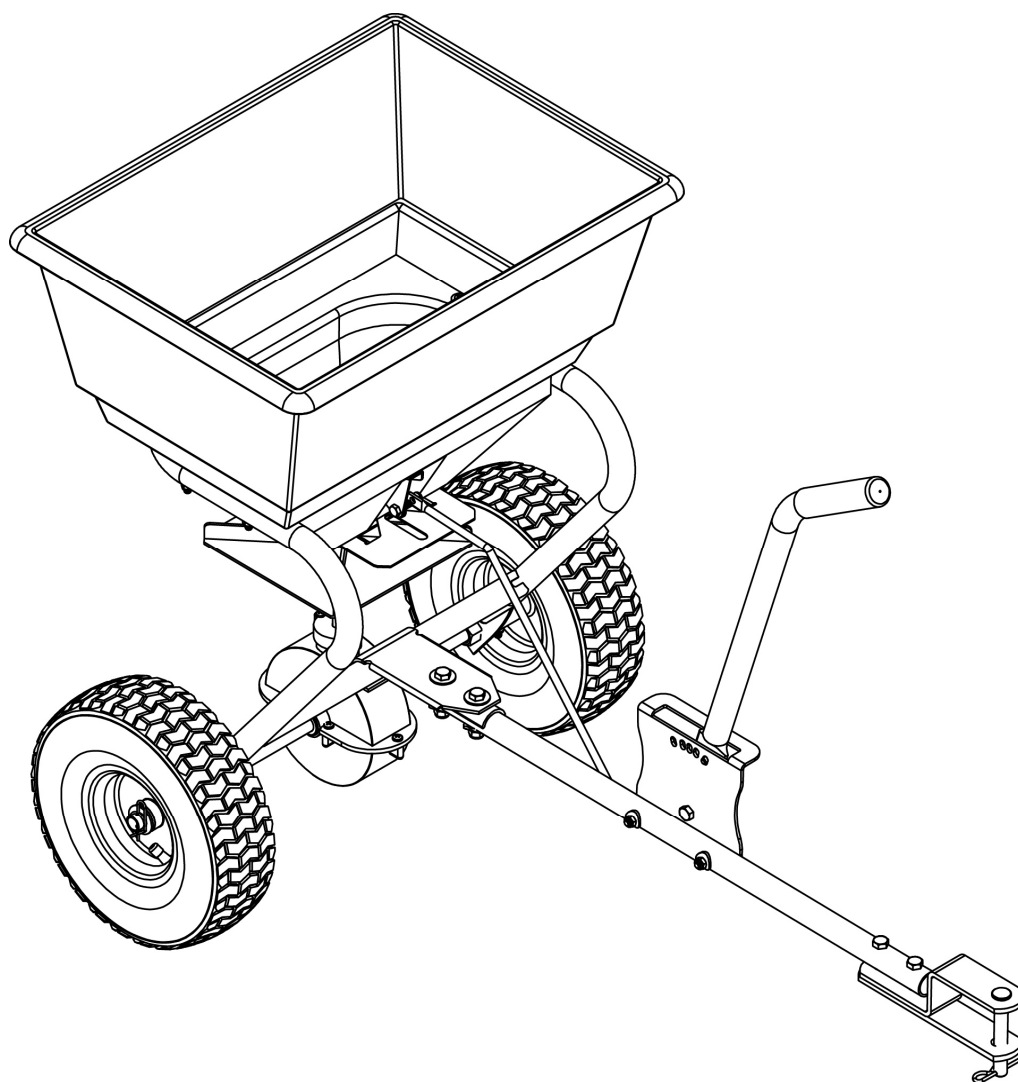

Instruction & Assembly

SAVE THESE INSTRUCTIONS FOR FUTURE REFERENCE

SAFETY RULES

READ THE DIRECTIONS BEFORE ASSEMBLY

- Read the towing vehicle owners manual and towing vehicle safety rules. Know how to operate your tractor before using the tow-behind spreader.
- Read the chemical label instructions and cautions for handling and applying the chemicals purchased for spreading.
- Wear eye and hand protection when handling and when applying lawn or garden chemicals.
- Never operate tractor and spreader attachment without wearing substantial footwear, and do not allow anyone to ride or sit on spreader attachment frame.
- Never allow children to operate the tractor or spreader attachment, and do not allow adults to operate without proper instructions.
- Always begin with the transmission in first (low) gear and with the engine at low speed, and gradually increase speed as conditions permit.
- When towing spreader do not drive too close to a creek or ditch and be alert for holes and other hazards which could cause you to loose control of the spreader and tractor.
- Before operating vehicle on any grade (hill) refer to the safety rules in the vehicle owner's manual

PROP 65 WARNING

This product can expose you to chemicals including lead and lead compounds which are known to the State of California to cause cancer and birth defects or other reproductive harm. For more information, go to www.P65Warnings.ca.gov.

REMOVE AND IDENTIFY LOOSE PARTS FROM CARTON AND BAG

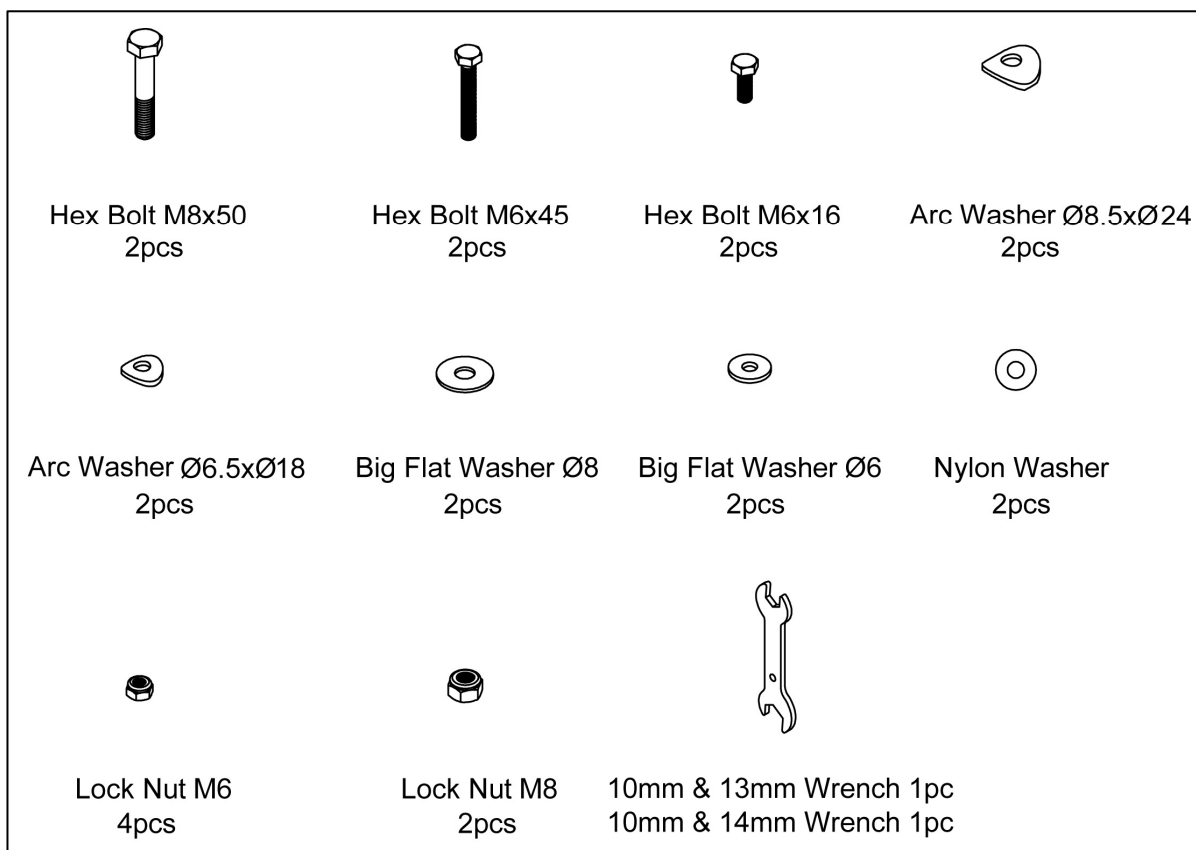
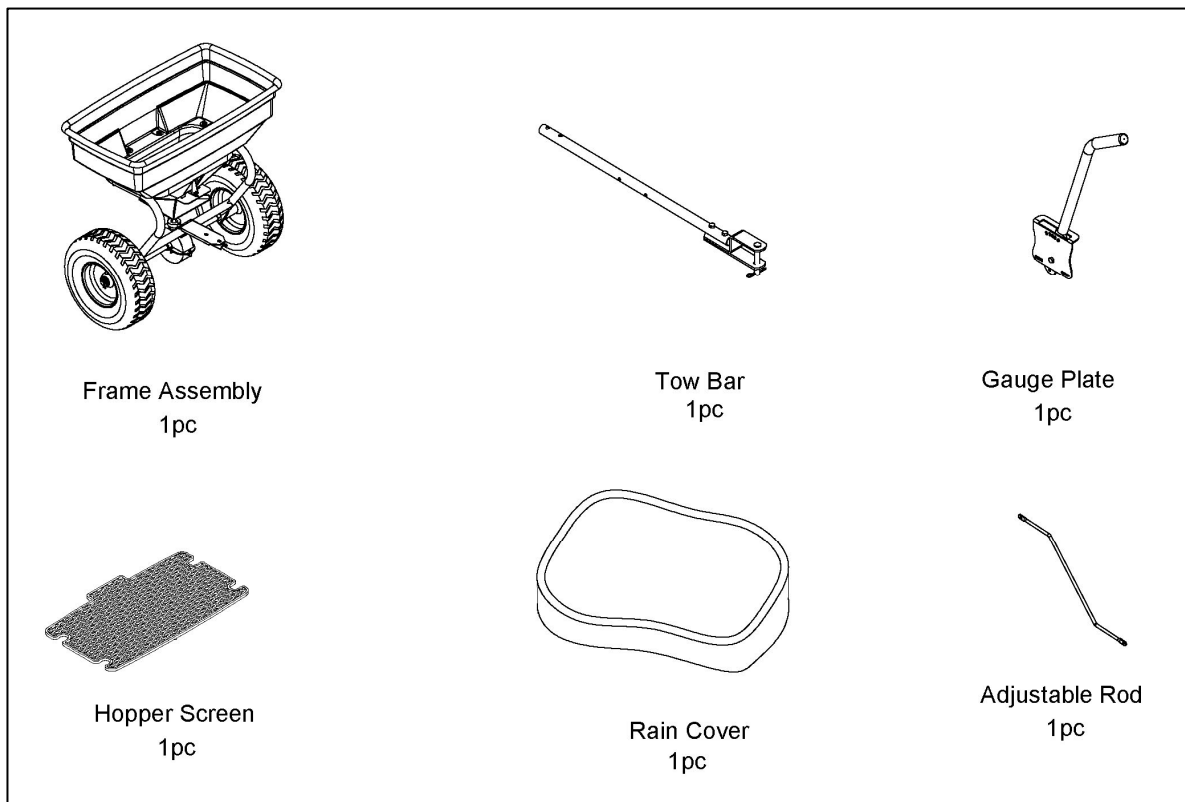

ASSEMBLY INSTRUCTIONS

1. Attach tow bar (#31) to the frame tube assembly (#14) using hex bolt M8x50 (#21), big flat washer Ø8 (#22), arc washer Ø8.5x Ø24 (#28) and lock Nut M8 (#29).
2. Attach the gauge plate (#38) to the tow bar (#31) using hex bolt M6x45 (#26), big flat washer Ø6 (#37), arc washer Ø6.5x Ø18 (#30) and lock Nut M6 (#13). Don't tighten the nuts.
3. Attach the upper end of adjustable rod (#42) to the fix plate for adjustable rod (#12) using hex bolt M6x16 (#11), nylon washer (#2) and lock nut M6 (#13). After the lock nut is tightened, turn back 1/2 circle.
4. Attach the lower end of the adjustable rod (#42) to the handle (#40) using hex bolt M6x16 (#11), nylon washer (#2) and lock Nut M6 (#13). After the lock nut is tightened, turn back 1/2 circle. Regulate the adjust plate as required above, then tighten all bolts and nuts.

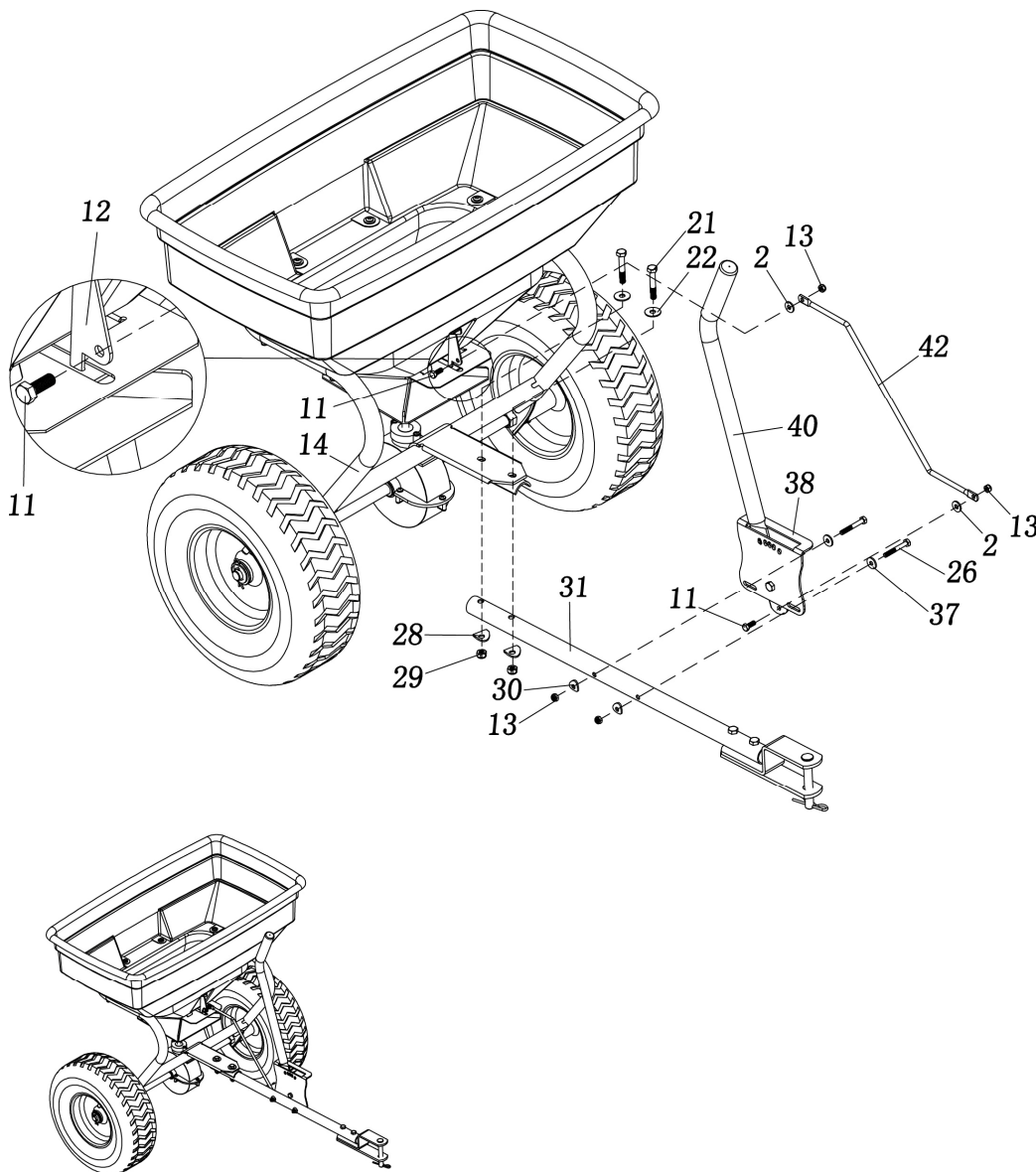

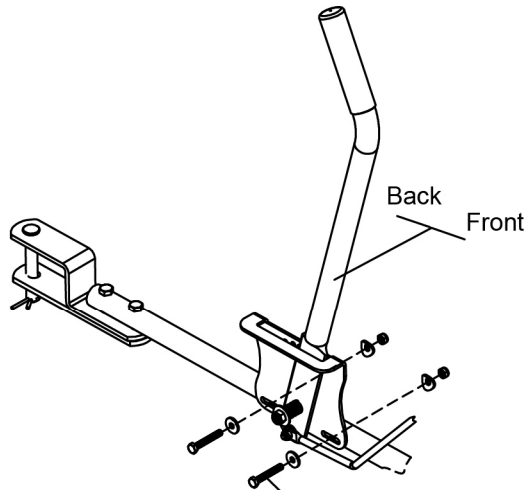

3. Adjusting the handle to make sure the adjustable plate is fully open or closed, if not, please loosen the hex bolt M6x40 and lock nut M6, pull the control rod to make sure the adjustable plate is fully open or closed, then tighten the nuts.

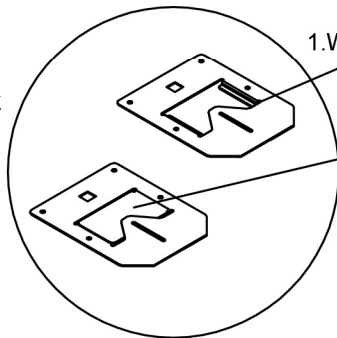
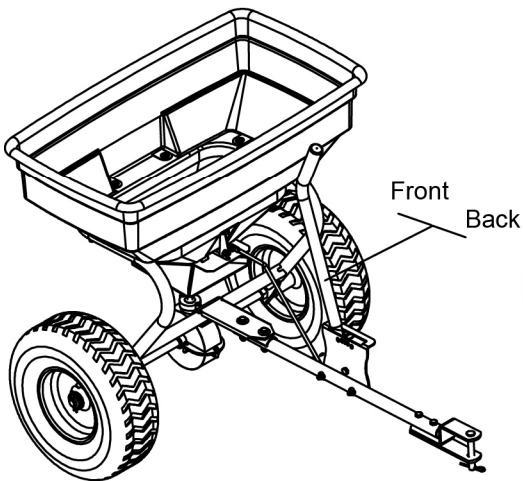

1. When the handle push to the end, the adjustable plate is fully open.

2. When the handle push back to the end, the adjustable plate is fully closed.

Lubricate the wheel axle and bushing with grease through the oil nipples per 20 hours.

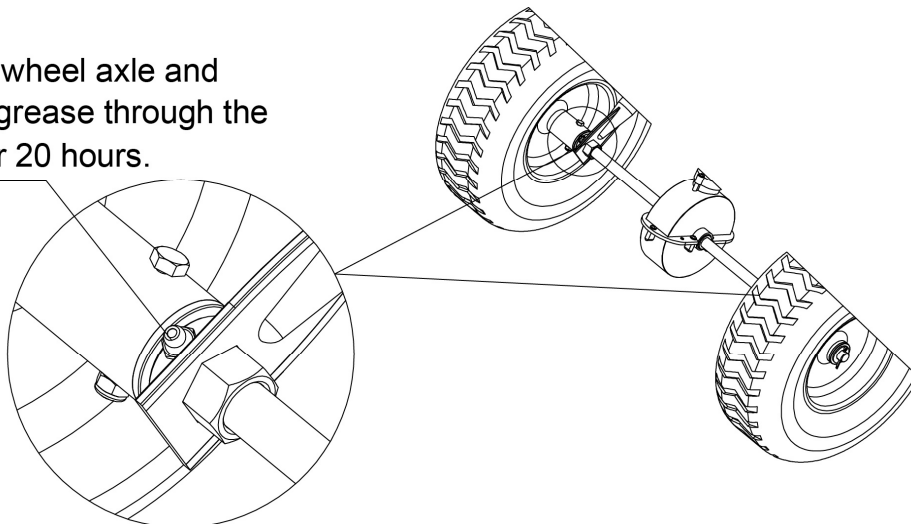

SPECIFICATION
Capacity: 125LB / 60L
Dimension of Hopper: 29-1/2in.x16-1/2in.x13-2/5in. (75x42x34cm)
Length of Tow Bar: 29-1/8in. (74cm)
Net Weight: 38.36lb/17.4kg
Overall Size: 42-1/8in.x30-1/4in.x30-3/8in. (107x76.7x77cm)
Wheel Diameter: 14-1/4in. (36cm)
Wheel Width: 5-1/8in. (13cm)

 **GENERAL WARNINGS** 

Operator must read and understand all safety and warning information, operating instructions, maintenance and storage instructions before operating this equipment. Failure to properly operate and maintain the lawn roller could result in serious injury to the operator or bystanders.

Operation Warnings

- **DO NOT** at any time carry passengers sitting or standing on the lawn roller.
- **DO NOT** allow children to play on, stand upon or climb on the spreader.
- **DO NOT** exceed rated capacity of 125lb
- Replace or repair damaged or worn parts immediately.
- To avoid personal injury and/or equipment damage **DO NOT EXCEED 5 MPH.**
- **ONLY** tow with recommended vehicles (Lawn/Garden Tractors and ATVs).
- **ALWAYS** inspect the spreader before using to assure it is in good working condition.
- **ALWAYS** keep hands and feet clear from moving parts while operating the equipment.
- **DO NOT** use if the spreader is damaged or worn as this may cause injury to the operator or bystanders.
- **ALWAYS** make sure the spreader is secure and locked to the hitch of the approved vehicle before operating.
- **NEVER** add material to the spreader unless it is attached to the tractor.

Maintenance and Storage

MAINTENANCE

- After each use clean material out of hopper.
- Rinse/dry inside and outside of the spreader after each use.
- Before operating make sure the tires have the RECOMMENDED TIRE PRESSURE.
- Periodically check all fasteners for tightness.
- Annually clean and lightly lubricate parts.
- Use a glossy enamel spray paint to touch up scratched or worn painted metal surfaces.
- Never exceed load capacity rating of 125lbs it will damage the spreader.

IMPORTANT:

If a part needs replacement, only use parts that meet the manufacturer's specifications. Replacement parts that do not meet specifications may result in a safety hazard or poor operations.

STORAGE

- Never allow material to remain in the hopper for extended periods of time.
- Before storing make sure the spreader is clean and dry for years of trouble free service.
- Store indoors or protected area during severe weather and winter months.

WARNING

ALWAYS maintain the proper tire pressure. **DO NOT** over or under inflate the tires as serious injury may result. **ALWAYS** keep the tires at **20PSI**.

PARTS DRAWING

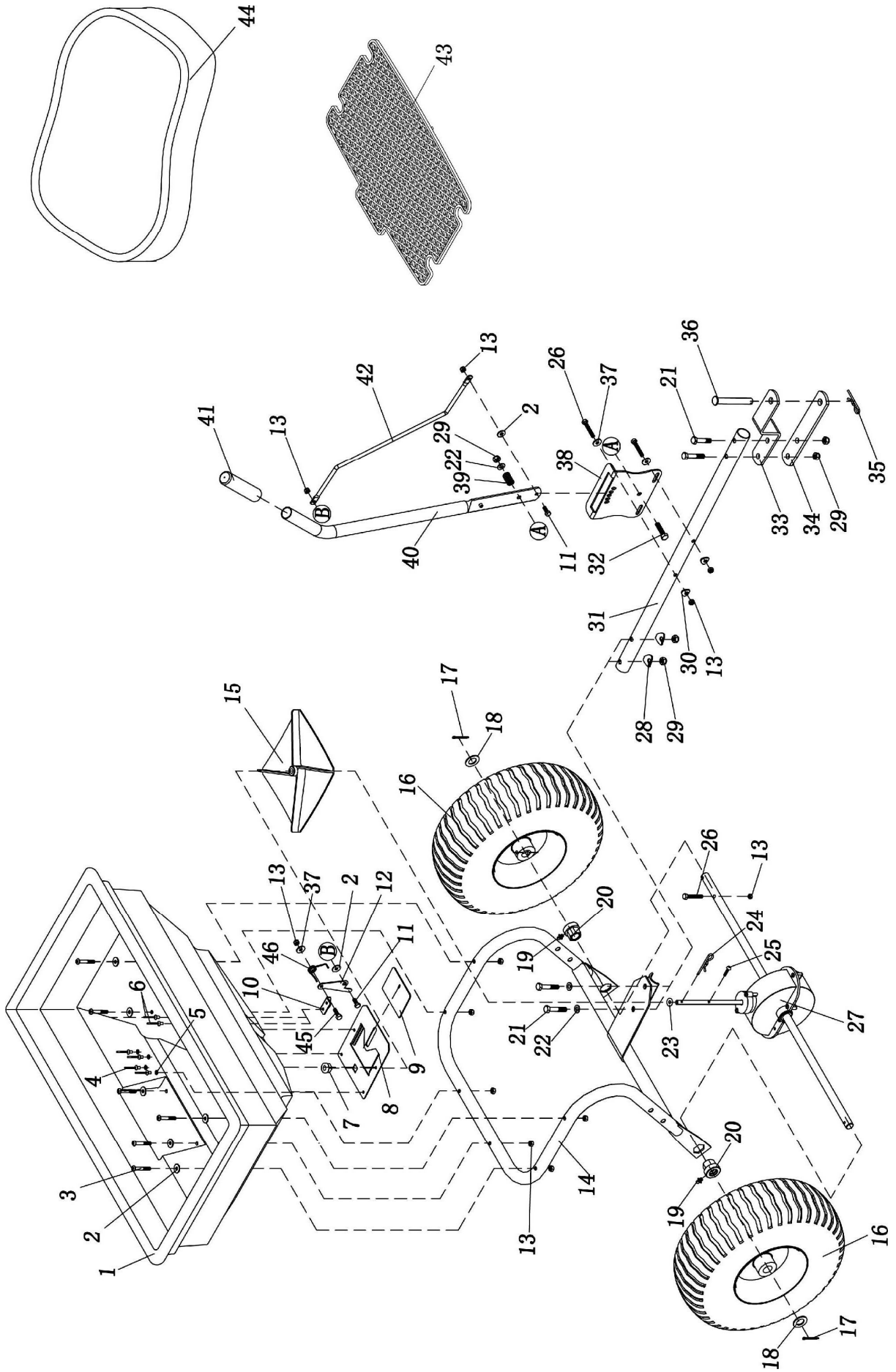

PARTS LIST

Ref#	Drawing No.	Description	Qty
1	N512-00020	Hopper Assembly	1
2	BS1200-0009	Nylon Washer	8
3	9104-06045-BXG	Inner Hex Screw M6x45	6
4	9504-05013-YH	Open End Blind Rivet M5x13	4
5	9301-05000-BXG	Flat Washer Ø5	4
6	9504-05008-YH	Open End Blind Rivet M5x8	2
7	N512-00009	Swivel Axle Bushing	1
8	BS1200-00001-PG	Fixed Adjustable Plate	1
9	BS1200-00002-PG	Active Adjustable Plate	1
10	N512-00023-CD	Base for Torsion Spring	1
11	9101-06016-CD	Hex Bolt M6x16	2
12	BS1200-00013-CD	Fix Plate for Adjustable Rod	1
13	9206-06000-CD	Lock Nut M6	12
14	BT1200-01000	Frame Tube assembly	1
15	N514-00004	Impeller	1
16	BS1200-03000	Wheel	2
17	9404-03030-CD	Cotter Pin Ø3x30	2
18	9301-16000-CD	Flat Washer (1.5t)	2
19	9701-06000	Oil Cup M6	2
20	BS1200-00004-CD	Wheel Axle Bushing	2
21	9101-08050-CD	Hex Bolt M8x50	4
22	9302-08000-CD	Big Flat Washer Ø8	3
23	N575-00014	Thin Gasket	1
24	N565-00009	R Pin	1
25	9110-04020-CD	Cross Recessed Pan Head Screw M4x20	1
26	9101-06045-CD	Hex Bolt M6x45	3
27	BS1200-04000	Gearbox	1
28	BS1200-00008-CD	Arc Washer Ø8.5x Ø24	2
29	9206-08000-CD	Lock Nut M8	5
30	BS1200-00014-CD	Arc Washer Ø6.5x Ø18	2

Ref#	Drawing No.	Description	Qty
31	BT1200-00001	Tow Bar	1
32	9101-08035-CD	Hex Bolt M8x35	1
33	N100-00014	Connecting Plate	1
34	N280-00025	Screw Adjustment Plate	1
35	N021-00004-CD	R Pin Ø3	1
36	N770-00004-CD	Pin	1
37	9302-06000-CD	Big Flat Washer Ø6	3
38	BS1200-00011	Gauge Plate	1
39	CPR150B-00008-CD	Spring	1
40	BT1200-02000	Handle	1
41	BS0700-00002	Handle Grip	1
42	BT1200-00002	Adjustable Rod	1
43	N575-00008	Hopper Screen	1
44	BS1200-00010	Rain Cover	1
45	9101-06020-CD	Hex Bolt M6x20	1
46	N512-00025-CD	Torsion Spring	1

Limited Warranty

Warranty

For one year from the date of purchase YTL International will replace for the original purchaser, or repair the spreader. The warranty will not apply to any unit which was not assembled correctly, misused, overloaded or which has been used or operated contrary to our instructions, or which has been repaired or altered by anyone other than an authorized representative.

Warranty Exclusions

This warranty does not cover cosmetic defects such as paint, decals or wear items such as tires. This warranty will not cover failures or problems due to acts of God, or events or forces beyond the control of the manufacturer.

Normal Wear Exclusion

The spreader needs periodic service to perform well. This warranty does not cover repair when normal use has exhausted the life of a part or the equipment as a whole.

Installation, Use and Maintenance Exclusion

This warranty will not apply to parts and/or labor if the spreader has been misused, neglected, involved in an accident, abused, loaded beyond its limits, modified or assembled incorrectly. Normal maintenance is not covered under this warranty.

Limits of Implied Warranty and Consequential Damage Exclusion

YTL International disclaims any obligation to cover any loss of time, use of this product, freight, or any incidental or consequential claim by anyone from using this spreader. THIS WARRANTY IS IN LIEU OF ALL OTHER WARRANTIES, EXPRESS OR IMPLIED, INCLUDING WARRANTIES OF MERCHANTABILITY OR FITNESS FOR A PARTICULAR.

An exchange unit will be subject to the original warranty. The length of the warranty governing the exchanged unit will have the date as the purchase date of the original unit. This warranty gives you certain legal rights which may change from state to state. Your state may also have other rights you may be entitled to that are not listed within this warranty.

Contact Information

YTL International

17517 Fabrica Way, Suite H

Cerritos, CA 90703

Phone: (888) 723-6534

Phone: (562) 404-8016

Fax: (562) 404-8013

Email: parts@ytlinternational.com

Web: www.ytlinternational.com