

# 125LB ALL PURPOSE SPREADER



## Instruction & Assembly

SAVE THESE INSTRUCTIONS FOR FUTURE REFERENCE

# Table of Contents

General Warnings and Rules .....	3
Hazard Signal Word Definitions.....	4
Component & Hardware.....	5
Assembly Instructions .....	6
Operation Instructions .....	7, 8
Maintenance and Storage .....	9
Specification .....	9
Parts Drawing & Parts List .....	10, 11, 12
Limited Warranty .....	13

## **GENERAL WARNINGS**

**READ and UNDERSTAND this manual completely before using All Purpose Spreader.**

Operator must read and understand all safety and warning information, operating instructions, maintenance and storage instructions before operating this equipment. Failure to properly operate and maintain the push spreader could result in serious injury to the operator or bystanders.

### **Operation Warnings**

- Do not at any time carry passengers sit or stand on the spreader.
- Do not allow children to play on, stand upon or climb in the spreader.
- Always inspect the spreader before using to assure it is in good working condition.
- Replace or repair damaged or worn parts immediately.
- Always check and tighten hardware and assembled parts before operation.
- Do not exceed equipment maximum load capacity of 125lb.
- Avoid large holes and ditches when transporting loads.
- Be careful when operating on steep grades (hill) the spreader may tip over.
- Do not push close to creeks, ditches and public highways.
- Do not use spreader on windy days when spreading grass seed or herbicides.
- Always use caution when loading and unloading spreader.
- Never tow the spreader with a motorized vehicle.

### **Crush and Cut Hazards**

- Always keep hands and feet clear from moving parts while operating the equipment.
- Always clear and keep work area clean when operating.
- Always wear safety gear, eye protection, gloves and work boots when operating the spreader.

### **WARNING**

The warnings, cautions, and instructions outlined in this instruction manual cannot cover all possible conditions or situations that may occur. It must be understood by the operator that common sense and caution are factors which cannot be built into this product and must be supplied by the operator.





### **PROP 65 WARNING**

This product can expose you to chemicals including lead and lead compounds which are known to the State of California to cause cancer and birth defects or other reproductive harm. For more information, go to [www.P65Warnings.ca.gov](http://www.P65Warnings.ca.gov).

### **Assembly Is Required**

This product requires assembly before use. See "Assembly" section for instructions. Because of the weight and/or size of the push spreader, it is recommended that another adult be present to assist with the assembly. **INSPECT ALL COMPONENTS** closely upon receipt to make sure no components are missing or damaged.

# Hazard Signal Word Definitions

	<p>This is the safety alert symbol. It is used to alert you to potential personal injury hazards. Obey all safety messages that follow this symbol to avoid possible injury or death.</p>
	<p><b>DANGER</b> indicates an imminently hazardous situation which, if not avoided, will result in death or serious injury.</p>
	<p><b>WARNING</b> indicates a potentially hazardous situation which, if not avoided, could result in death or serious injury.</p>
	<p><b>CAUTION</b> indicates a potentially hazardous situation which, if not avoided, may result in minor or moderate injury.</p>
	<p><b>CAUTION</b> used without the safety alert symbol indicates a potentially hazardous situation which, if not avoided, may result in property damage.</p>

## ABOUT YOUR PUSH SPREADER

This push spreader is designed to spread a wide range of materials (Fertilizer, Grass Seed and Ice melt). Materials such as Powders, Manure, Top Soil, Gravel, and Mulch have the wrong physical characteristics and should not be used with this spreader. Never exceed the rated load capacity of 125lbs when operating the spreader.

Your spreader needs to be pushed at three miles per hour, which is a brisk walking speed. Slower or faster speeds will change the spread patterns. Wet spreading material will also change the spread pattern and flow rate. Clean your spreader thoroughly after each use. Wash between the shut off plate and bottom of the hopper.

Technical specifications on the push spreader are provided in the “Specifications” section of this manual.

# Component Parts

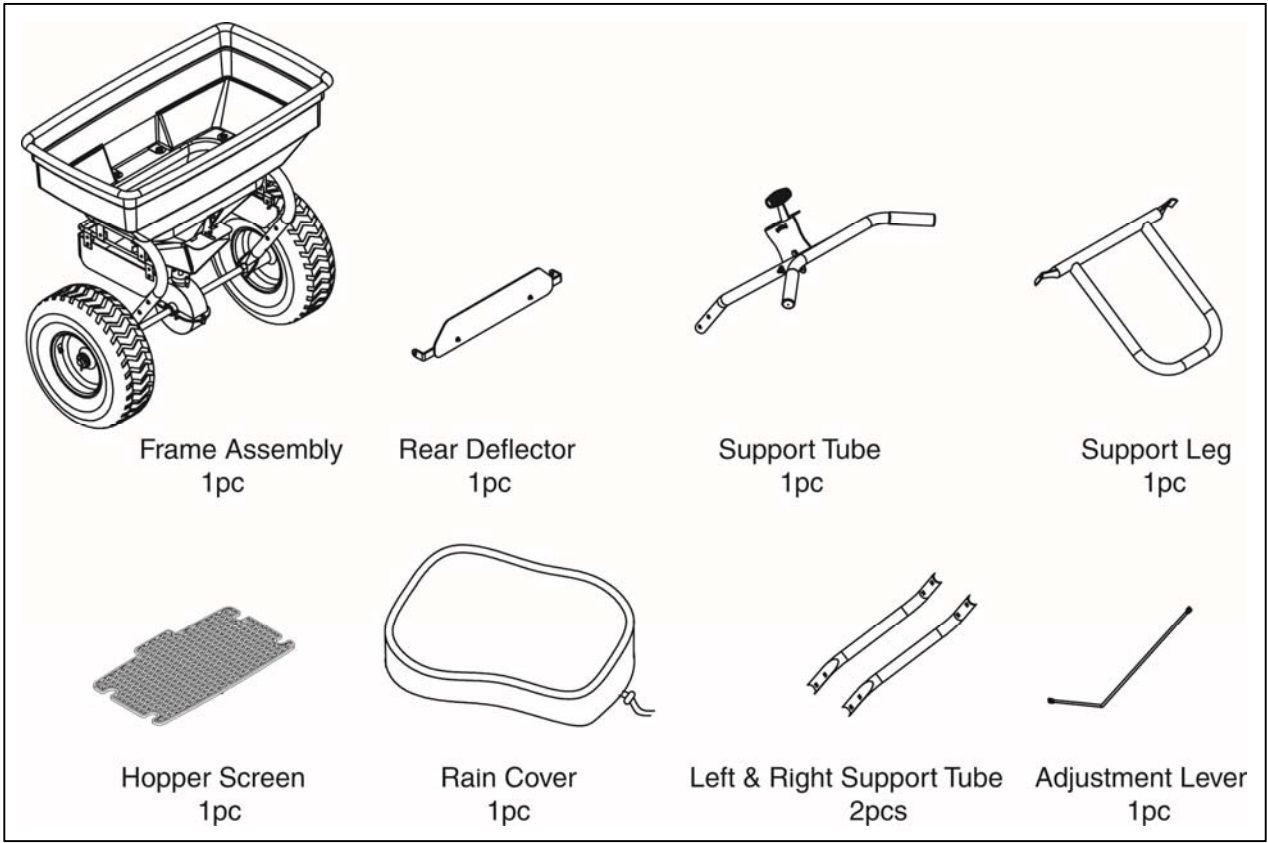

Frame Assembly  
1pc

Rear Deflector  
1pc

Support Tube  
1pc

Support Leg  
1pc

Hopper Screen  
1pc

Rain Cover  
1pc

Left & Right Support Tube  
2pcs

Adjustment Lever  
1pc

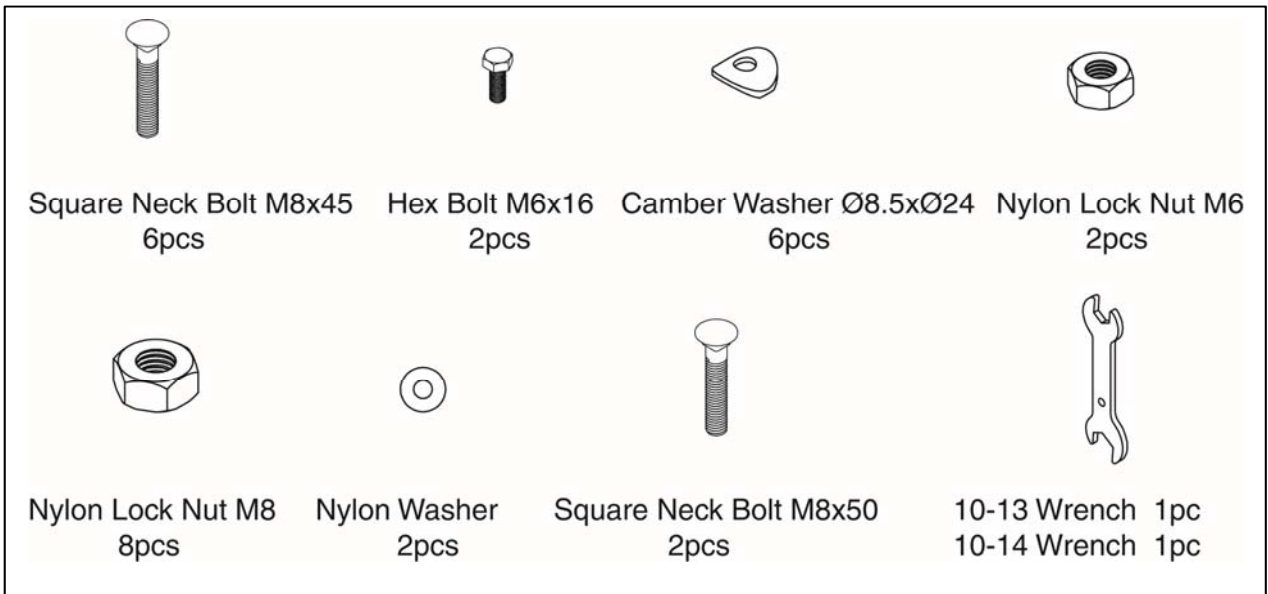

Square Neck Bolt M8x45  
6pcs

Hex Bolt M6x16  
2pcs

Camber Washer Ø8.5xØ24  
6pcs

Nylon Lock Nut M6  
2pcs

Nylon Lock Nut M8  
8pcs

Nylon Washer  
2pcs

Square Neck Bolt M8x50  
2pcs

10-13 Wrench 1pc  
10-14 Wrench 1pc

# Assembly Instructions

## STEP 1: Installing the Support Leg

1. Attach the support leg (#30) to the installation tube assembly (#14) using square neck bolt M8x45 (#48), camber washer (#22) and nylon lock nut M8 (#20).
2. Attach the left and right support tube (#28) to the installation tube assembly (#14) using square neck bolt M8x45 (#48), camber washer (#22) and nylon lock nut M8 (#20). **ONLY lightly tighten the nuts.**
3. Attach the rear deflector (#56) to the installation tube assembly (#14) using square neck bolt M8x45 (#48) and nylon lock nut M8 (#20).

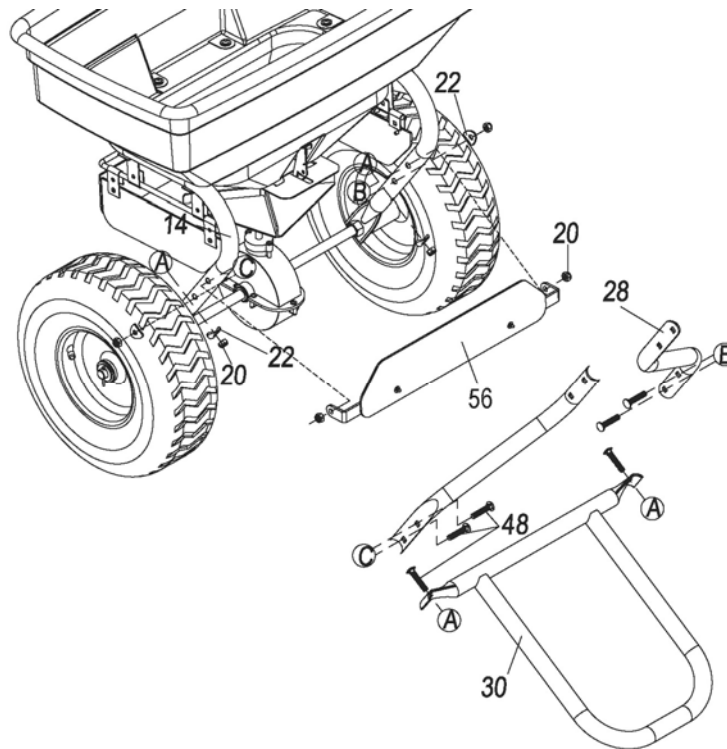

## STEP 2: Installing the Handle

1. Attach the handle connecting tube (#32) to the left and right support tube (#28) using square neck bolt M8x50 (#29), camber washer (#22) and nylon lock nut M8 (#20). **Tighten all nuts.**
2. Connect the lower adjustment lever (#31) to the connecting rod fixed plate (#12) using hex bolt M6x16 (#11), nylon washer (#2) and nylon lock nut M6 (#13). Tighten the nuts, then back a circle, the nut lower than bolt. Repeat the step of upper adjustment lever (#31) to the handle (#40).

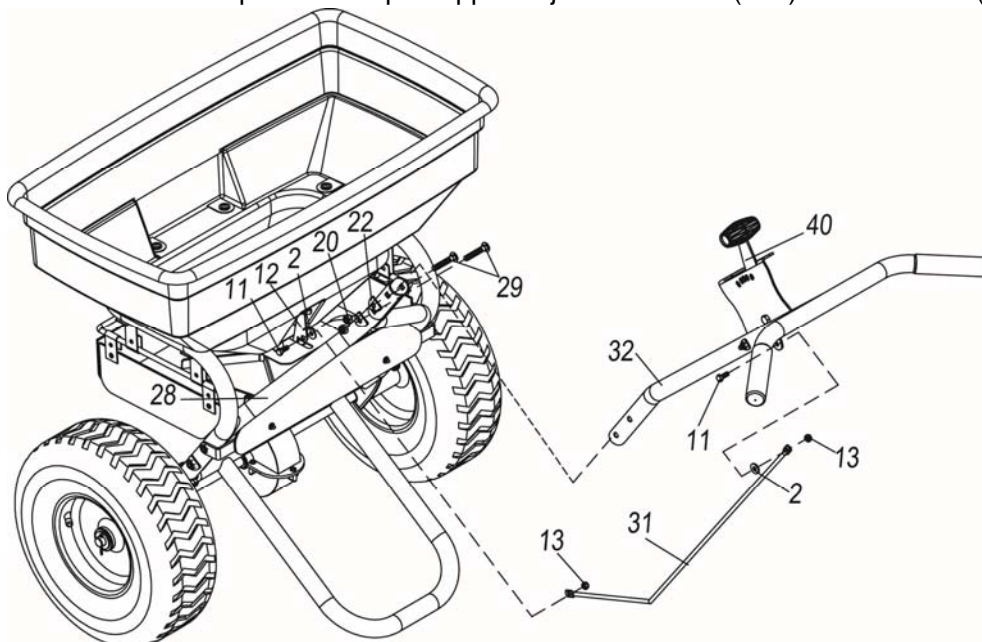

# Operation Instructions

## WARNING

Before using the push spreader, review the instructions below and safety information. Failure to follow these instructions may result in property damage or injury to the operator or bystanders.

### USING YOUR SPREADER

1. Inspect your spreader before each use. Make sure the wheels turn easily, and the gearbox moves when the spreader is pushed. The hopper should be clean and free from cracks.
2. Spreader is designed to spread a range of materials (Fertilizer, Grass Seed and Ice melt). Materials such as Powder, Manure, Top Soil, Gravel, and Mulch have the wrong physical characteristics and should not be used with your spreader
3. Do not use spreader on windy days when spreading grass seed or herbicides.
4. Determine approximate square footage of the area to be covered and estimate amount of material required. Please refer to fertilizer manufacturer's recommendation. Break up any lumpy fertilizer as you fill the hopper.
5. Before filling the hopper, make sure that the flow control lever is in the "0" position and the flow control plate is closed.
6. Set the adjustable stop with the flow control lever always in the "0" position. Every time you are ready to stop or turn back, close the flow control plate to stop dispersing the material and continue one more stride. This reduces waste and avoids damaging the lawn with oversaturated product coverage.
7. Follow fertilizer manufacturer's recommended coverage rate for each product
8. To maintain the same coverage when walking at a different speed, adjust the flow rate. Reduce the flow setting for slower speeds and increase the flow setting for higher speeds.
9. Keep the impeller plate horizontal when operating the spreader. Tilting the spreader will result in uneven coverage.
10. Make sure the R pin is installed in the hopper before starting the spreader.
11. Always start walking prior to opening the closure plate.
12. Always close the flow control plate before turning or stopping the spreader.
13. If spreading material is accidentally deposited too heavily in a small area, soak the area thoroughly with a garden hose or sprinkler to prevent burning of the lawn.
14. To insure consistent coverage, make sure each broadcast pattern slightly overlaps the previous broadcast pattern.
15. When broadcasting spreading material, make sure the broadcast pattern does not hit evergreen trees, flowers or shrubs.
16. Do not over apply spreading material. Follow the recommended coverage rate for each product. Over application will lead to lawn damage and contamination.

# Operation Instructions

## ADJUSTING THE FLOW

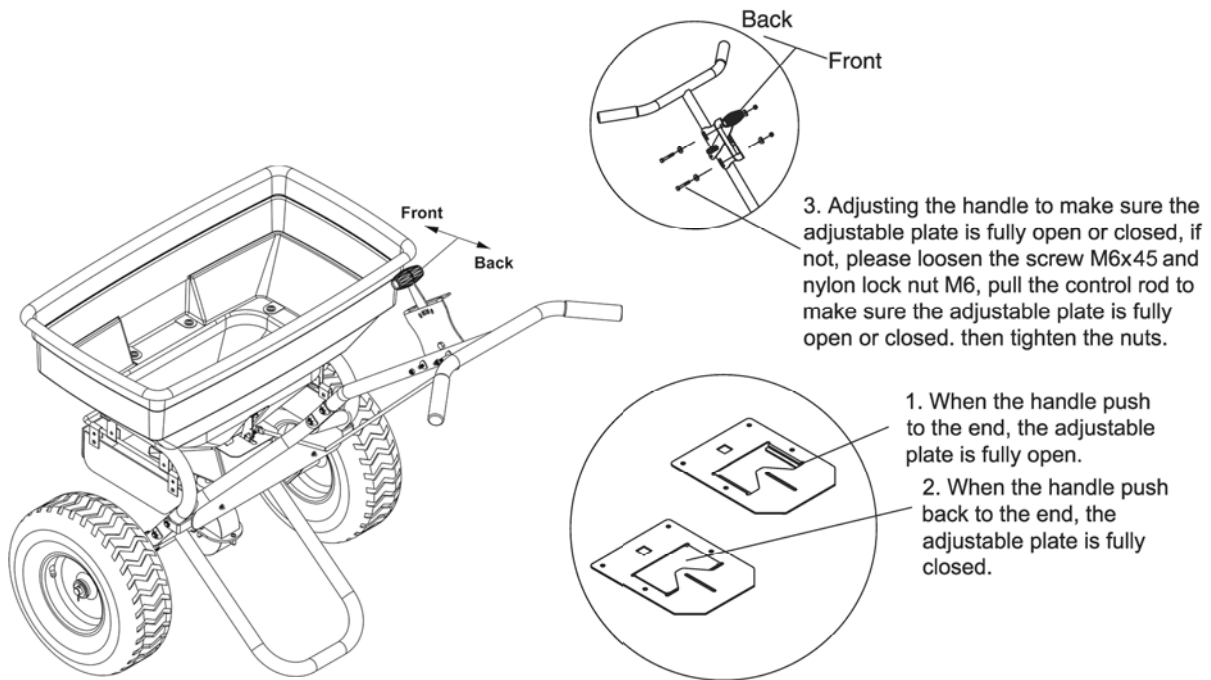

## CONSISTENT COVERAGE

To insure consistent coverage, make sure each broadcast pattern slightly overlaps the previous broadcast pattern as shown in figure below. The approximate broadcast widths for different materials are shown in the application chart.

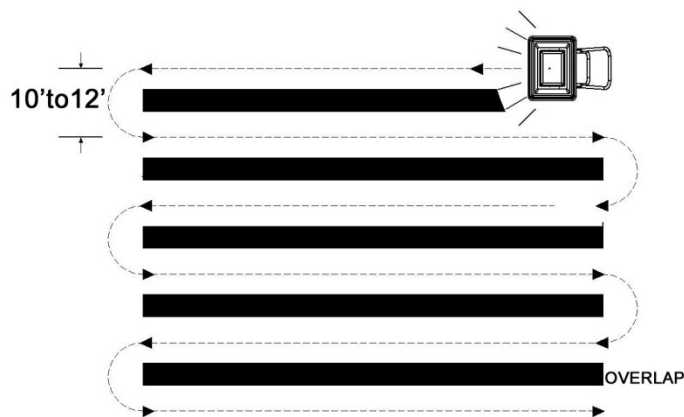

### **WARNING**

Do not over apply spreading material. Follow the recommended coverage rate for each product. Over application will lead to damage and contamination. If spreading material accidentally hits or deposits too heavily, soak the area thoroughly with a garden hose or sprinkler to prevent burning.



# Maintenance and Storage



## WARNING

Improper maintenance and storage of the push spreader may void your warranty.

## MAINTENANCE

- After each use clean material out of hopper.
- Rinse/dry inside and outside of the spreader after each use.
- Before operating make sure the tires have the RECOMMENDED TIRE PRESSURE 20 PSI.
- Periodically check all fasteners for tightness.
- Annually clean and lightly lubricate parts.
- Use a glossy enamel spray paint to touch up scratched or worn painted metal surfaces.
- Never exceed load capacity rating of 125lbs it will damage the spreader.

### **IMPORTANT:**

If a part needs replacement, only use parts that meet the manufacturer's specifications. Replacement parts that do not meet specifications may result in a safety hazard or poor operation.

## STORAGE

- Never allow material to remain in the hopper for extended periods of time.
- Before storing make sure the spreader is clean and dry for years of trouble free service.
- Store indoors or protected area during severe weather and winter months.

# Specifications

Load Capacity .....	125lb
Spreader Type .....	Broadcast
Hopper Material .....	Polypropylene
Hopper Dimensions .....	29 1/2" x 16 1/2" x 13 1/2"
Overall Dimensions .....	45.6" x 30.2" x 37.8"
Wheel size .....	14"
Tire Pressure (PSI) .....	20

# Parts Drawing & Parts List

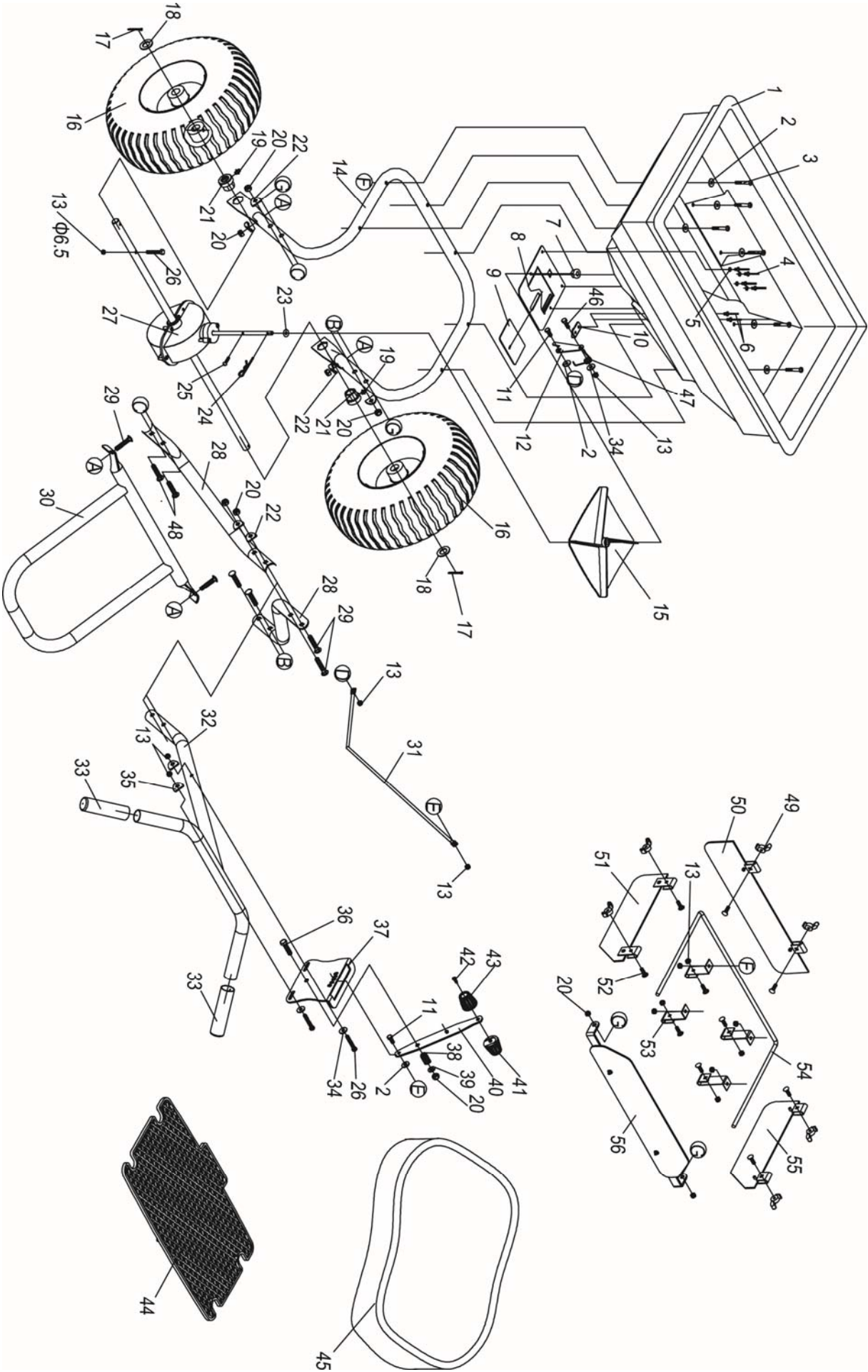

## Parts Drawing & Parts List

Ref#	Drawing No.	Description	Qty
1	N512-00020	Hopper	1
2	BS1200-00009	Nylon Washer	8
3	9104-06045-BXG	Inner Hex Bolt M6x45	6
4	9504-05013-YH	Open Type Blind Rivet M5x13	4
5	9301-05000-BXG	Flat Washer Ø5	4
6	9504-05008-YH	Open Type Blind Rivet M5x8	2
7	N512-00009	Revolving Shaft Sleeve	1
8	BS1200-00001-PG	Fixed Adjustable Plate	1
9	BS1200-00002-PG	Active Adjustable Plate	1
10	BS0701-00004	Torsional Spring Fixed Plate	1
11	9101-06016-BXG	Hex Bolt M6x16	2
12	BS1201-00013-BXG	Connecting Rod Fixed Plate	1
13	9206-06000-BXG	Hex Lock Nut M6	12
14	BS1201-00003	Installation Tube	1
15	N514-00004	Impeller	1
16	BS1200-03000	Wheel	2
17	9404-03030-BXG	Cotter Pin Ø3x30	2
18	9301-16000-BXG	Flat Washer Ø16	2
19	9701-06000	Oil Cap M6	2
20	9206-08000-BXG	Hex Lock Nut M8	9
21	BS1201-00004-BXG	Hex Wheel Axle Sleeve	2
22	BS1201-00008-BXG	Camber Washer Ø8.5x Ø24	8
23	N575-00014	Thin Washer	1
24	N021-00004	R Pin	1
25	9110-04020-BXG	Screw M4X20	1
26	9101-06045-BXG	Hex Bolt M6x45	3
27	BS1201-04000	Gear Box	1
28	BS1201-00006	Left & Right Support Tube	2
29	9114-08050-BXG	Square Neck Bolt M8x50	2
30	BS1201-02000	Support Leg	1

<b>Ref#</b>	<b>Drawing No.</b>	<b>Description</b>	<b>Qty</b>
31	BS1201-00005	Adjustment Lever	1
32	BS1201-01000	Handle Connecting Tube	1
33	BS1200-00007	Handle Sleeve	2
34	9302-06000-BXG	Big Flat Washer Ø6	3
35	BS1201-00014-BXG	Camber Washer Ø6.5xØ18	2
36	9101-08035-BXG	Hex Bolt M8x35	1
37	BS1201-00011	Graduated Plate	1
38	CPR150B-00008-CD	Spring	1
39	9302-08000-BXG	Big Flat Washer Ø8	1
40	BS1201-05000	Handle	1
41	N570-00015	Adjustable Handle B	1
42	9118-04018-BXG	Screw M4X18	1
43	N570-00014	Adjustable Handle A	1
44	N575-00003	Screen	1
45	BS1200-00010	Rain Cover	1
46	9101-06020-BXG	Hex Bolt M6x20	1
47	N512-00025-CD	Torsional Spring	1
48	9114-08045-BXG	Square Neck Bolt M8x45	6
49	9299-06000-BXG	Wing Nut M6	6
50	BS1201-06100	Front Deflector	1
51	BS1201-06200	Left Deflector	1
52	9114-06020-BXG	Square Neck Bolt M6x20	10
53	N571-00003-BXG	Plate	4
54	N571-00004-BXG	Hanging Rod	1
55	BS1201-06300	Right Deflector	1
56	BS1201-06400	Rear Deflector	1

# Limited Warranty

## **Warranty**

For one year from the date of purchase YTL International will replace for the original purchaser, or repair the push spreader. The warranty will not apply to any unit which was not assembled correctly, misused, overloaded or which has been used or operated contrary to our instructions, or which has been repaired or altered by anyone other than an authorized representative.

## **Warranty Exclusions**

This warranty does not cover cosmetic defects such as paint, decals or wear items such as tires. This warranty will not cover failures or problems due to acts of God, or events or forces beyond the control of the manufacturer.

## **Normal Wear Exclusion**

The spreader needs periodic service to perform well. This warranty does not cover repair when normal use has exhausted the life of a part or the equipment as a whole.

## **Installation, Use and Maintenance Exclusion**

This warranty will not apply to parts and/or labor if the spreader has been misused, neglected, involved in an accident, abused, loaded beyond its limits, modified or assembled incorrectly. Normal maintenance is not covered under this warranty.

## **Limits of Implied Warranty and Consequential Damage Exclusion**

YTL International disclaims any obligation to cover any loss of time, use of this product, freight, or any incidental or consequential claim by anyone from using this spreader. THIS WARRANTY IS IN LIEU OF ALL OTHER WARRANTIES, EXPRESS OR IMPLIED, INCLUDING WARRANTIES OF MERCHANTABILITY OR FITNESS FOR A PARTICULAR.

An exchange unit will be subject to the original warranty. The length of the warranty governing the exchanged unit will have the date as the purchase date of the original unit. This warranty gives you certain legal rights which may change from state to state. Your state may also have other rights you may be entitled to that are not listed within this warranty.

## **Contact Information**

YTL International  
17517 Fabrica Way, Suite H  
Cerritos, CA 90703  
Phone: (888) 723-6534  
Phone: (562) 404-8016  
Fax: (562) 404-8013  
Email: [parts@ytlinternational.com](mailto:parts@ytlinternational.com)  
Web: [www.ytlinternational.com](http://www.ytlinternational.com)